

High Pressure Pump Series HDP MC

1100 kW

Design criteria

Hammelmann high pressure pumps are built to operate at the continuous maximum duty stated in the performance parameters. Just compare the crankshaft speed, average plunger speed, plunger diameter and power rating.



High pressure pump
Weight: 5361 kg

Features

- Power ratings up to 1100 kW
- Vertical 7 cylinder design
- Wide variety of complementary ancillaries

Quality and reliability

- Stainless steel pump head free of alternating stress
- Cross head piston bellows seal
- Choice of 'application specific' seal assemblies
- Solid ceramic or tungsten carbide plungers
- Choice of bronze or stainless steel suction chamber
- Crank section calculation by 'Finite element method' ensures long working life under continuous load
- Twin helical integral reduction gear with crankshaft supported by 4 bearings
- Pressurised oil lubrication system with oil cooler/filter

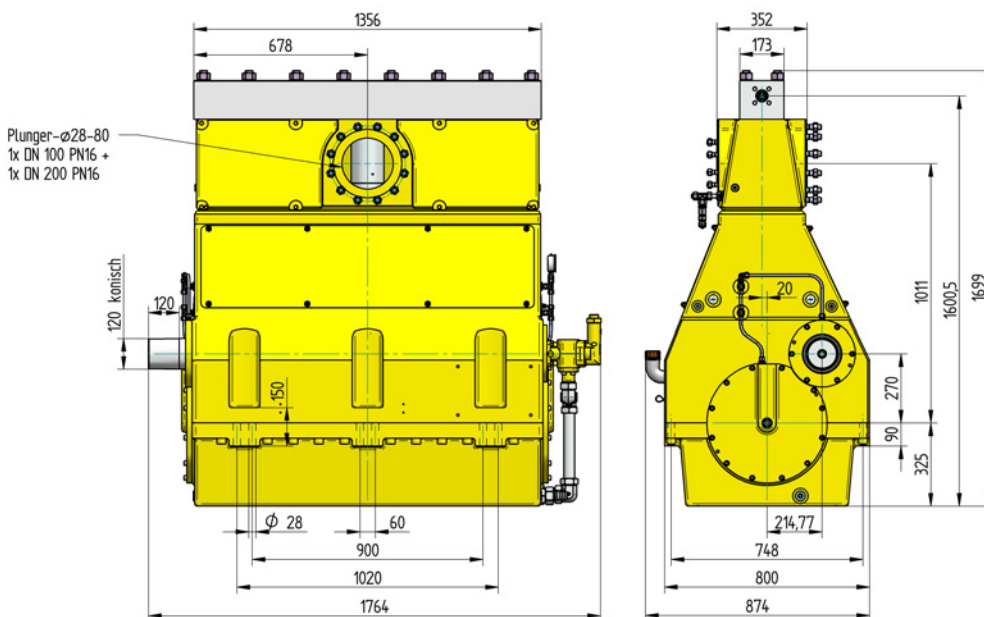

01/21 © Copyright Hammelmann GmbH, Oelde, Germany. Subject to modification.

Hammelmann GmbH

Carl-Zeiss-Straße 6-8
59302 Oelde • Germany
mail@hammelmann.de

Telefon (0 25 22) 76-0
Telefax (0 25 22) 76-140
www.hammelmann.de

HAMMELMANN®

HDP MC series, technical data

Performance parameters (Standard design)

1100 kW

HDP	Q [l/min]	Required power rating [kW]					D	r.p.m.	
		710	800	900	1000	1100		n 1	n 2
		Operating pressure [bar]							
MC 4	124* 149* 178*	2900*	3000*	3000*			28	1500 1500/1800 1800	320 385 460
	166 / 164* 199 / 197* 238 / 236*	2300* 1870 1560	2500* 2100* 1760	2600* 2400* 1980	2900*	3000*	32	1500 1500/1800 1800	320 385 460
	203 / 198* 244 / 239* 291 / 285*	1880 1560 1310	2100* 1760 1470	2200* 1980 1660	2200*	2000*	35	1500 1500/1800 1800	320 385 460

*Ultra high pressure

MC 3	267 322 384	1440 1200 1000	1620 1350 1130	1670 1510 1270	1670 1670 1410	1550	40	1500 1500/1800 1800	320 385 460
	342 411 492	1140 940 800	1280 1060 900	1320 1200 1000	1320 1320 1110	1220	45	1500 1500/1800 1800	320 385 460

MC 2	422 508 607	920 760 640	1040 860 720	1070 970 810	1070 1070 900	1000	50	1500 1500/1800 1800	320 385 460
	506 608 727	760 630 530	860 710 600	880 800 670	880 880 750	820	55	1500 1500/1800 1800	320 385 460
	608 732 874	640 530 440	720 600 500	740 670 560	740 740 630	700	60	1500 1500/1800 1800	320 385 460
	721 867 1036	550 450 370	610 510 430	630 570 480	630 630 530	600	65	1500 1500/1800 1800	320 385 460
	836 1006 1202	470 390 320	530 440 370	550 500 410	550 550 460	510	70	1500 1500/1800 1800	320 385 460
	960 1155 1380	410 340 280	460 380 320	480 430 360	480 480 400	440	75	1500 1500/1800 1800	320 385 460
	1058 1273 1521	360 290 240	400 340 280	420 380 320	420 420 350	400	80	1500 1500/1800 1800	320 385 460

MC 1 High flow	1058 1273 1521	360 300 250	400 340 280	420 380 320	420 420 350	400	80	1500 1500/1800 1800	320 385 460
	1195 1438 1718	320 260 220	360 300 250	370 340 280	370 370 310	340	85	1500 1500/1800 1800	320 385 460
	1354 1629 1946	280 240 200	320 270 220	330 300 250	330 330 280	310	90	1500 1500/1800 1800	320 385 460
	1689 2032 1428	230 200 160	260 220 180	270 240 200	270 270 230	250	100	1500 1500/1800 1800	320 385 460
	2065 2484 2968	200 160 130	210 180 150	220 200 170	220 220 200	200	110	1500 1500/1800 1800	320 385 460

Note: Actual flow rates for water as pumped medium (volumetric efficiency has already been taken into account).

- Rod force: 210 kN
- Stroke: 100 mm
- Mean piston speed at n₂
320 r.p.m. = 1,06 m/sec
385 r.p.m. = 1,28 m/sec
460 r.p.m. = 1,54 m/sec

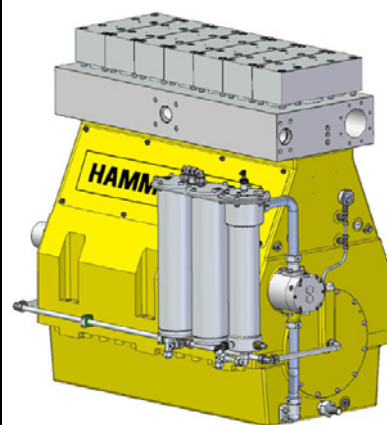

D = Piston/Plunger dia. [mm]
n1 = Motor/Engine r.p.m. [1/min]
n2 = Crankshaft r.p.m.[1/min]

Conversion table
Rating 1 kW = 1.34 HP
Op. pressure 1 bar = 14.5 psi
Flow rate 1 l = 0.264 US gallon
1 l = 0.22 Imp. gallon

HDP	Seal **	Sealing system
MC4	Dynamic D 28	Tungsten carbide plunger & bushing
	Dynamic D 35	Tungsten carbide plunger / bronze bushing
MC3	Dynamic	Ceramic plunger / bronze bushing
	Packing	Ceramic plunger / packing
MC2	Dynamic D 50 -75	Ceramic plunger / bronze bushing
	Packing D 50 - 80	Ceramik plunger / packing
MC1	Packing	Ceramik plunger / packing

** The dynamic high pressure sealing extends the advantages of the labyrinth design with further increased efficiency.

HAMMELMANN®