

# High Pressure Pump Series HDP 800

## Design criteria

Hammelmann high pressure pumps are built to operate at the continuous maximum duty stated in the performance parameters. Just compare the crankshaft speed, average plunger speed, plunger diameter and power rating.

Energy  
efficient →



## High pressure pump

Weight: approx. 8,170 lbs

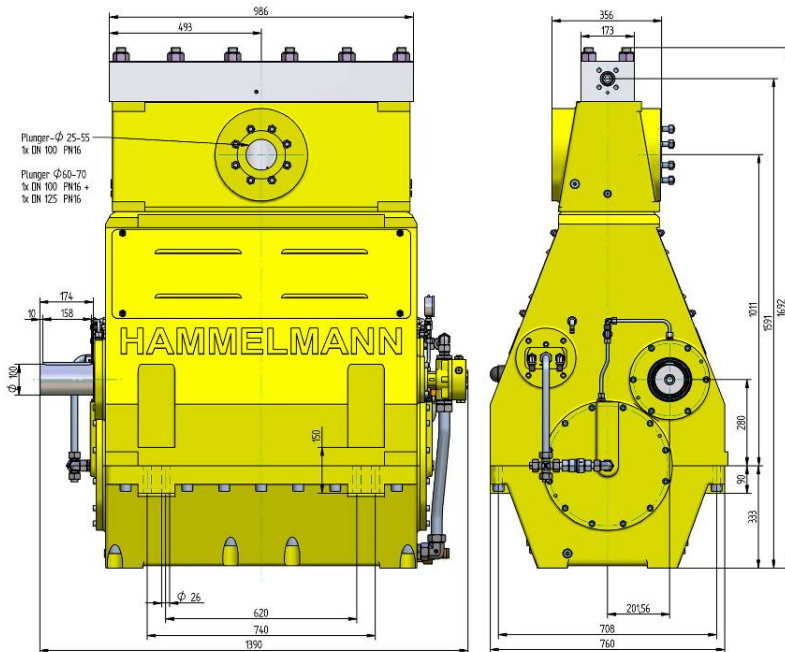

## Stationary unit with diesel engine

Length: 156 inch  
Width: 83 inch  
Height: 87 inch  
Weight: approx. 20,300 lbs  
at 1100 HP and  
without full fuel tank

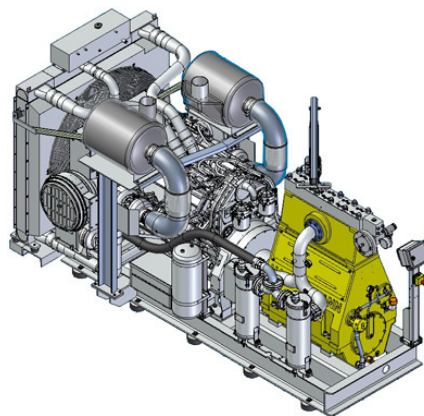

Main dimensions without accessories such as suction line, pressure regulator etc. All shown as right side drive. Detailed dimensional drawings and weights available on request.

## Features

- Power ratings up to 1070 HP
- Vertical 5 cylinder design
- Wide variety of complementary ancillaries

## Quality and reliability

- Stainless steel pump head free of alternating stress
- Cross head piston bellows seal
- Choice of 'application specific' seal assemblies
- Solid ceramic or tungsten carbide plungers
- Choice of bronze or stainless steel suction chamber
- Crank section calculation by 'Finite element method' ensures long working life under continuous load
- Twin helical integral reduction gear with crankshaft supported by 4 bearings
- Pressurised oil lubrication system with oil cooler/filter

Hammelmann Corp. 436 Southpointe Drive  
Miamisburg, Ohio 45342  
eMail: mail@hammelmann.com

Phone (001) 937-859-8777  
Fax: (001) 937-859-9188  
http://www.hammelmann.com

**HAMMELMANN®**

# HDP 800 series, technical data

## Performance parameters (Standard design)

**Note: Actual flow rates for water as pumped medium (volumetric efficiency has already been taken into account).**

HDP	Q [IGPM]	Required power rating [HP]					D	r.p.m.		
		670	750	840	950	1070		n 1	n 2	
		Operating pressure [psig]								
804	23.0	43500*					28	1500	315	
	27.7	36300*	40600*	43500*				1500/1800	380	
	34.1	30500*	34100*	37700*	42100*	43500*		1800	465	
	130.1*	32600*	36500*					1500	315	
804	37.5 / 36.2*	27000	30200*	34100*	37700*		32	1500/1800	380	
	45.7 / 44.4*	22000	24700	27800	31200*	35400*		1800	465	
804	37.2 / 36.7*	26800	31200*	31900*			35	1500	315	
	44.9 / 43.8*	21800	24700	28300	31900*			1500/1800	380	
804	54.9 / 53.6*	18100	20300	23200	26100	30500*	1800	1800	465	
	* Ultra high pressure									
803	49.9	20700	23200	24200			40	1500	315	
	59.9	17100	19100	21500	24200			1500/1800	380	
	72.9	14200	16000	17800	20200	22800		1800	465	
803	61.8	16400	17700	19100			45	1500	315	
	74.2	13500	15100	17000	19100			1500/1800	380	
	90.3	11200	12600	14100	16000	18000		1800	465	
802	77.1	13300	14900	15500			50	1500	315	
	92.4	10900	12200	13800	15500			1500/1800	380	
	112.7	9100	10200	11500	12900	14500		1800	465	
	802	94.2	11000	12300	12800			55	1500	315
		113.3	9000	10200	11300	12800			1500/1800	380
		137.8	7500	8400	9400	10600	12000		1800	465
	802	113.5	9300	10300	10700			60	1500	315
		136.2	7500	8400	9600	10700			1500/1800	380
		165.8	6200	7100	8000	9000	10000		1800	465
	802	134.4	7800	8800	9100			65	1500	315
		161.3	6400	7300	8100	9100			1500/1800	380
		196.7	5400	6000	6800	7700	8600		1800	465
802	156.0	6800	7500	7800			70	1500	315	
	187.2	5500	6200	7000	7800			1500/1800	380	
	228.1	4600	5200	5800	6500	7400		1800	465	
802	178.2	5900	6400	6800			75	1500	315	
	214.9	4800	5400	6100	6800			1500/1800	380	
	261.9	280	4500	5100	5700	6400		1800	465	
802	197.5	5200	5800	5900			80	1500	315	
	236.8	4200	4800	5400	5900			1500/1800	380	
	288.8	3500	3900	4500	5100	5700		1800	465	
801 High flow	236.8	4500	5100	5400			85	1500	315	
	267.4	3800	4200	4800	5400			1500/1800	380	
	327.6	3000	3500	3900	4500	4900		1800	465	
	801 High flow	252.6	4100	4500	4800			90	1500	315
		303.1	3300	3800	4200	4800			1500/1800	380
		369.3	2800	3000	3500	3900	4500		1800	465
	801 High flow	315.0	3300	3600	3800			100	1500	315
		378.0	2800	3000	3300	3800			1500/1800	380
		460.7	2200	2500	2800	3200	3600		1800	465
	801 High flow	385.2	2800	3000	3200			110	1500	315
		462.3	2200	2500	2800	3200			1500/1800	380
		563.1	1900	2000	2300	2600	2900		1800	465

- Rod force: 47,200 lbf
- Stroke: 3.94 inch
- Mean piston speed at n<sub>2</sub>  
315 r.p.m. = 3.5 feet/sec  
380 r.p.m. = 4.2 feet/sec  
465 r.p.m. = 5.1 feet/sec

Typical high pressure pump units



- Stationary unit with diesel motor



- Diesel unit in container with workshop



- Stationary unit with electric motor

**Energy efficient** →

Hammelmann plunger pumps convert 93 to 98 % of the shaft power to hydraulic energy.

Conversion table

Rating 1 hp = 0,746 kW  
Op. pressure 1 psi = 0,069 bar  
Flow rate 1 gpm = 0,227 m<sup>3</sup>/h

D = Piston/Plunger dia. [mm]  
n1 = Motor/Engine r.p.m. [1/min]  
n2 = Crankshaft r.p.m. [1/min]

\*\* The dynamic high pressure sealing extends the advantages of the labyrinth design with further increased efficiency.

HDP	Seal**	Sealing system
804	Dynamic D 28	Tungsten carbide plunger & bushing
	Dynamic D 35	Tungsten carbide plunger / bronze bushing
803	Dynamic	Ceramic plunger / bronze bushing
	Packing	Ceramic plunger / packing
802	Dynamic D 50 -75	Ceramic plunger / bronze bushing
	Packing D 50 - 80	Ceramic plunger / packing
801	Packing	Ceramic plunger / packing

**HAMMELMANN®**