

HDP 200 High Pressure Pump Series

Design criteria

Hammelmann high pressure pumps are built to operate at the continuous maximum duty stated in the performance parameters. Just compare the crankshaft speed, average plunger speed, plunger diameter and power rating.

High pressure pump

Weight: approx. 525 kg

Energy efficient →

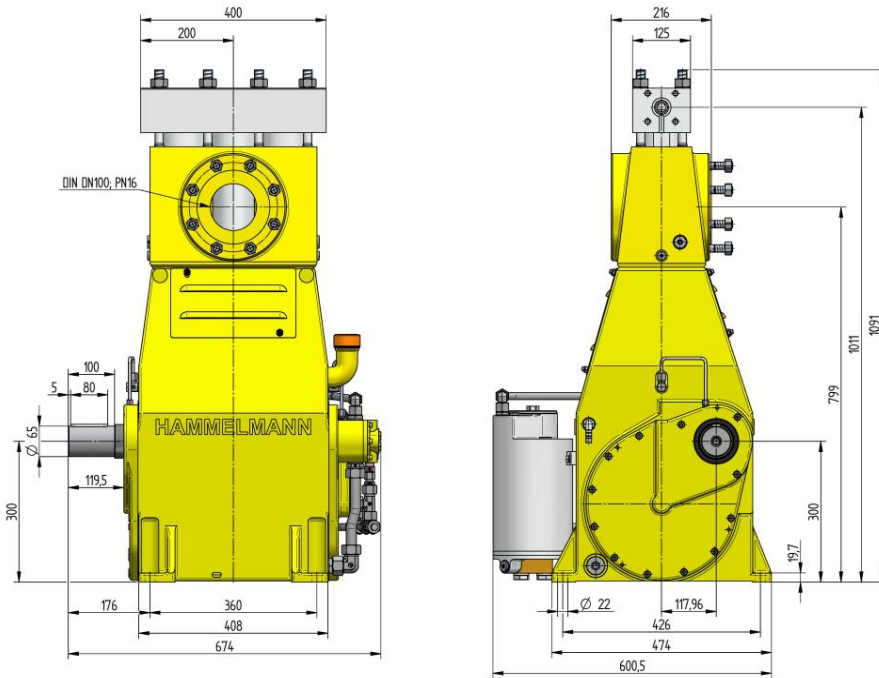

Features

- Power ratings up to 200 kW
- Vertical 3 cylinder design
- Wide variety of complementary ancillaries

Quality and reliability

- Crank section calculation by 'Finite element method' ensures long working life under continuous load
- Stainless steel pump head free of alternating stress
- Integral speed reduction gear
- Pressurised oil lubrication system with oil cooler/filter
- Bellows form hermetic seal between the suction chamber and crank section
- Solid ceramic or tungsten carbide plungers
- Choice of application specific seal assemblies
- Choice of bronze (standard) or stainless steel suction chamber

Stationary unit with electric motor

Length: 2038 mm
Width: 850 mm
Height: 1380 mm
Weight: approx. 2000 kg at 160 kW

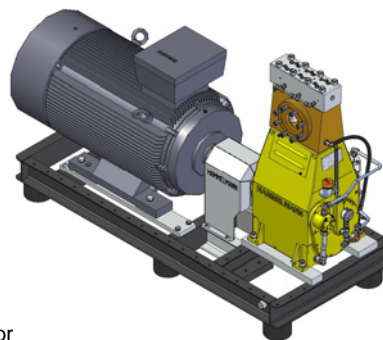

Main dimensions without accessories such as suction line, pressure regulator etc. Detailed dimensional drawings and weights available on request.

Stationary unit with diesel motor

Length: 2560 mm
Width: 1540 mm
Height: 2050 mm
Weight: approx. 3200 kg at 235 kW with full fuel tank

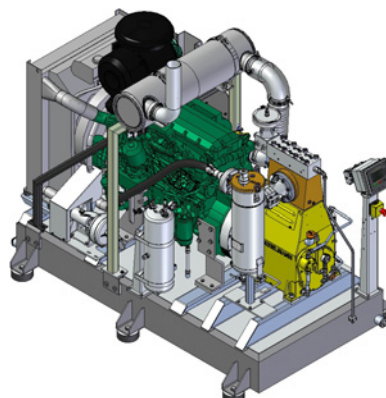

HDP 200 series, technical data

Performance parameters (Standard design)

Note: Actual flow rates for water as pumped medium (volumetric efficiency has already been taken into account).

HDP	Q [l/min]	Required power rating [kW]						D	r.p.m.		
		75	90	110	132	160	200		n 1	n 2	
		Operating pressure [bar]									
204	14*	2600*	3100*	3800*	4000*			15	1250/1500	416	
	17*	2200*	2600*	3200*	3800*	4000*			1500/1800	495	
	20*	1810	2200*	2700*	3200*	3900*	4000*		1800/2150	593	
	21/20*	25/24*	1900	2300*	2800*	3200*			17,5	1250/1500	416
		30/28*	1600	1910	2300*	2800*	3200*			1500/1800	495
			1330	1600	1950	2300*	2800*	3200*		1800/2150	593
	29/28*	34/33*	1450	1740	2100*	2600*	2800*		20	1250/1500	416
		41/39*	1220	1470	1800	2200*	2600*	2800*		1500/1800	495
			1020	1220	1500	1800	2200*	2700*		1800/2150	593
*Ultra high pressure 3200 bar only for stationary units											
203	44	930	1120	1360	1640	1800		25	1500	416	
	52	780	940	1150	1380	1670	1800		1500/1800	495	
	62	650	780	960	1150	1400	1740		1800/2150	593	
	55	740	900	1100	1310	1430		28	1500	416	
	65	620	750	910	1100	1300	1430		1500/1800	495	
	78	520	620	760	920	1110	1400		1800/2150	593	
202	61	650	780	950	1140	1240		30	1500	416	
	73	540	650	800	960	1160	1240		1500/1800	495	
	87	450	540	660	800	970	1210		1800/2150	593	
	78	530	640	780	940	1030		33	1500	416	
	92	450	540	660	800	960	1030		1500/1800	495	
	110	370	450	550	660	800	1000		1800/2150	593	
	84	470	570	700	840	910		35	1500	416	
	100	400	480	600	700	850	910		1500/1800	495	
	120	330	400	500	600	710	900		1800/2150	593	
	111	360	440	530	640	700		40	1500	416	
	132	310	370	450	540	650	700		1500/1800	495	
	158	250	310	370	450	540	680		1800/2150	593	
	143	300	340	420	510	550		45	1500	416	
	169	240	300	350	420	510	550		1500/1800	495	
	202	200	240	300	350	430	540		1800/2150	593	
	178	230	280	340	410	450		50	1500	416	
	211	200	230	300	340	420	450		1500/1800	495	
	252	160	200	240	300	350	440		1800/2150	593	
	216	200	230	280	340	370		55	1500	416	
	254	160	200	240	280	340	370		1500/1800	495	
	303	130	160	200	240	300	360		1800/2150	593	
	254	160	200	240	280	310		60	1500	416	
	300	140	160	200	240	300	310		1500/1800	495	
	359	110	140	170	200	240	300		1800/2150	593	
298	140	170	200	240	270		65	1500	416		
355	120	140	170	200	250	270		1500/1800	495		
425	100	120	140	170	210	260		1800/2150	593		
346	120	140	170	210	230		70	1500	416		
409	100	120	150	180	210	230		1500/1800	495		
489	80	100	120	150	180	220		1800/2150	593		

- Rod force: 88 kN
- Stroke: 75 mm
- Mean piston speed at n₂
416 r.p.m. = 1,04 m/sec
495 r.p.m. = 1,24 m/sec
593 r.p.m. = 1,48 m/sec

Typical high pressure pump units



- Mobile unit with electric motor



- Road going trailer or stationary units with sound damping cover



- 10 or 20 foot sound damped container versions

Energy efficient →

Hammelmann plunger pumps convert 93 to 98 % of the shaft power to hydraulic energy.

Conversion table
Rating 1 kW = 1.34 HP
Op. pressure 1 bar = 14.5 psi
Flow rate 1 l = 0.264 US gallon
1 l = 0.22 Imp. gallon

HDP	Seal **	Sealing system
204	Dynamic	Tungsten carbide plunger & bushing
	Packing	Special ceramic plunger *** / packing
203	Dynamic	Ceramic plunger / bronze bushing
	Packing	Ceramic plunger / packing
202	Dynamic	Ceramic plunger / bronze bushing
	Packing	Ceramik plunger / packing

D = Piston/Plunger dia. [mm]
n1 = Motor/Engine r.p.m.
n2 = Crankshaft r.p.m.

** The dynamic high pressure sealing extends the advantages of the labyrinth design with further increased efficiency.

*** Special ceramic plungers up to max. 3000 bar.